

UPS 25-60 A

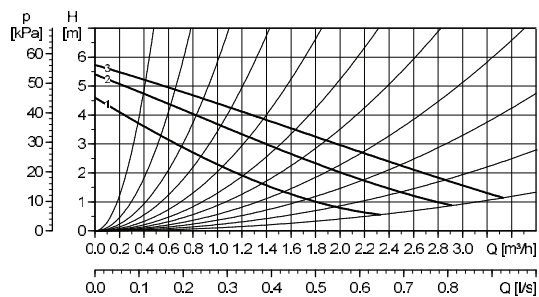

TM03 1062 1005

Electrical data 1 x 230 V, 50 Hz

Speed	P1 [W]	$I_{1/1}$ [A]
3	70	0.30
2	60	0.27
1	50	0.22

Dimensions

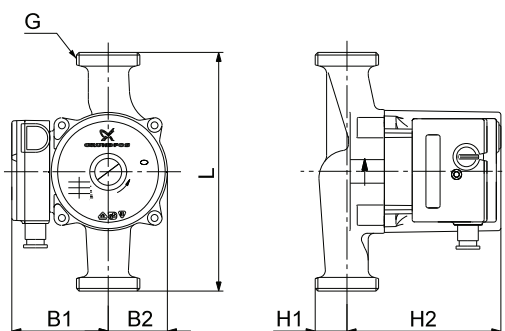

TM00 8945 2305

Connections: See [Pipe connections](#), page 85.
 System pressure: Max. 10 bar
 Liquid temperature: +2 to +110 °C (TF 110)
 Air separator, type A: Rp 3/8 thread for the air vent. The air vent is not supplied with the pump.

Pump type	Dimensions [mm]						Weights [kg]		Shipping volume [m ³]
	L	H1	H2	B1	B2	G	Net	Gross	
UPS 25-60 A	180	49	112	61	65	1 1/2"	3.5	3.7	0.0053